

Sistema de alavanca por tubo móvel para DN. 4" e acima

1	CORPO	AÇO INOX ASTM A351 GR. CF8
2	ESFERA	AÇO INOX ASTM A351 GR. CF8
3	FLANGE	AÇO INOX ASTM A351 GR. CF8
4	HASTE	AÇO INOX ASTM A351 GR. CF8
5	ALAVANCA	AÇO INOX ASTM A351 GR. CF8
6	SEDE DE VEDAÇÃO	PTFE
7	ANEL DE VEDAÇÃO	PTFE
8	ANEL PREME	AÇO INOX AISI 304
9	PARAFUSOS	A193 - GR. B7
10	PORCAS	A194 - GR. 2H

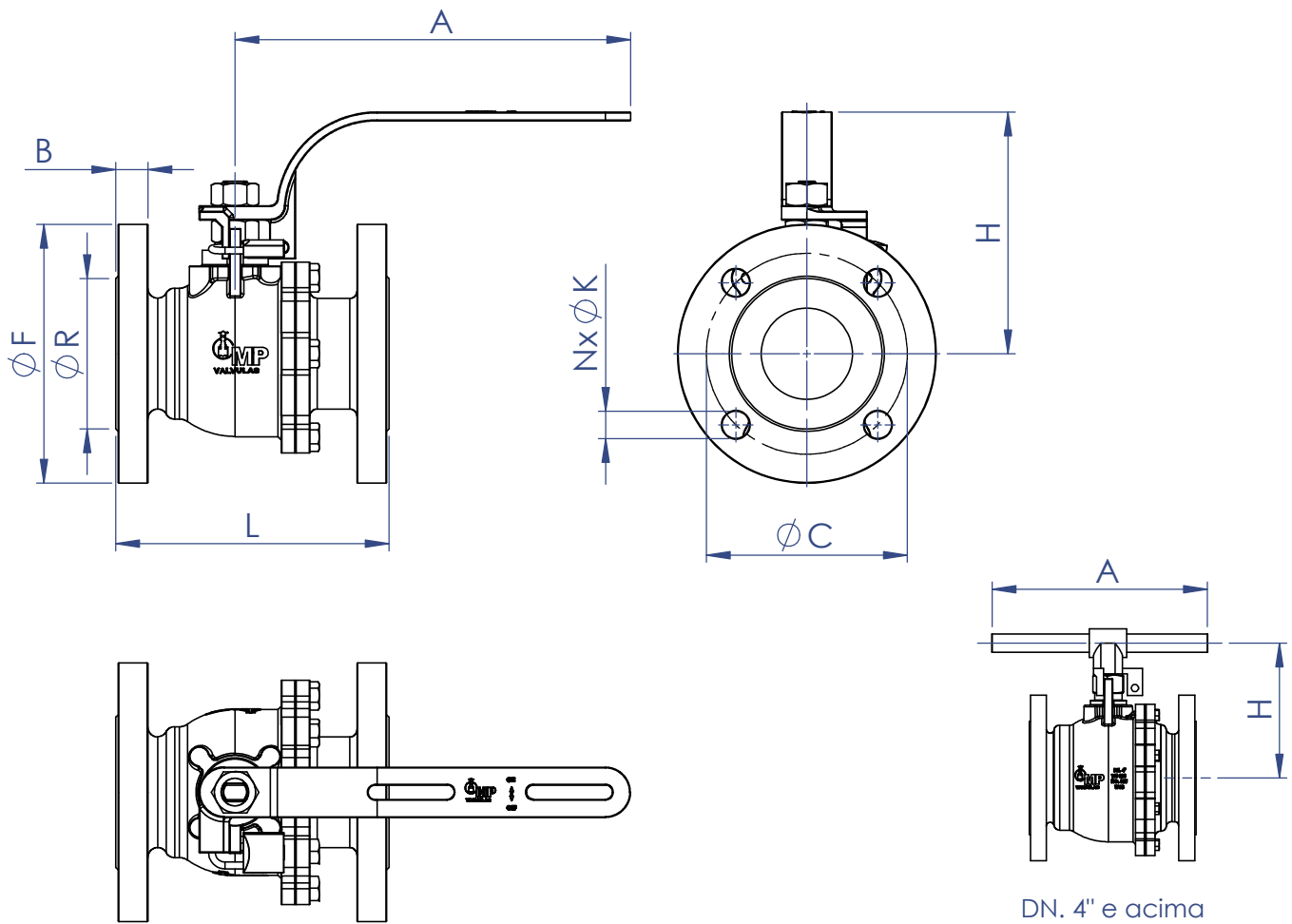

- OPÇÃO DE ACIONAMENTO POR ATUADOR PNEUMÁTICO DUPLA AÇÃO OU RETORNO MOLA
- EXCLUSIVO SISTEMA DE TRAVA PARA CADEADO EM SÉRIE
- HASTE A PROVA DE EXPULSÃO
- OPÇÃO DE ALAVANCA MICROFUNDIDA NO MESMO MATERIAL DO CORPO



DN	L	F	R	B	C	N	K	A	H
1/2"	108	90	34,9	11,2	60,3	4	5/8"	125	70
3/4"	117	100	42,9	12,7	69,9	4	5/8"	125	75
1"	127	110	50,8	14,3	79,4	4	5/8"	125	78
1.¼"	140	115	63,5	15,9	88,9	4	5/8"	170	100
1.½"	165	125	73	17,5	98,4	4	5/8"	170	105
2"	178	150	92,1	19,1	120,7	4	3/4"	170	115
2.½"	190	180	104,8	22,3	139,7	4	3/4"	275	170
3"	203	190	127	23,9	152,4	4	3/4"	275	180
4"	229	230	157,2	23,9	190,5	8	3/4"	480	200
6"	267	280	215,9	25,4	241,3	8	7/8"	600	250
8"	457	345	269,9	28,6	298,5	8	7/8"	600	325

**CARACTERÍSTICAS:**

NORMA DE CONSTRUÇÃO CONFORME  
ISO 17292, ASME B16.10 e ASME B16.34  
FLANGE CONFORME ANSI B16.5 (150LBS)  
NORMA DE TESTE CONFORME API 598

