

1	CORPO	BRONZE ASTM B62 C83600
2	TAMPA	BRONZE ASTM B62 C83600
3	MOLA	AÇO INOX AISI 302
4	CONTRA SEDE	BRONZE ASTM B62 C83600
5	ANEL DE VEDAÇÃO	PTFE

OPÇÕES DE MATERIAIS

- BRONZE ALUMÍNIO B148 C95200
- BRONZE ALUMÍNIO B148 C95500
- BRONZE ALUMÍNIO B148 C95800
- AÇO CARBONO ASTM A216 GR. WCB
- AÇO INOX ASTM A 351 GR. CF8
- AÇO INOX ASTM A351 GR. CF8M

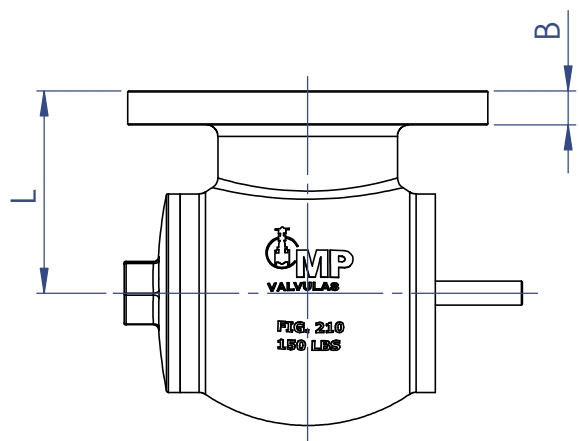

DN	L	F	B	C	N	K
2"	76	150	15,5	120,7	4	3/4"
3"	107	190	18	152,4	4	3/4"

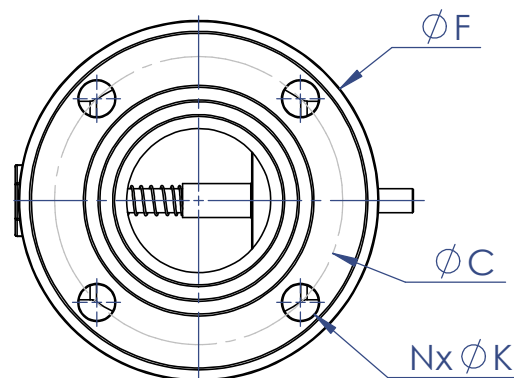

Construção conforme Padrão fabricante
Flanges conforme ANSI B16.5 para Aço
e B16.1 para Bronze
Teste conforme API 598

