

1	CORPO	AÇO INOX ASTM A 351 GR. CF8M
2	TAMPA	AÇO INOX ASTM A 351 GR. CF8M
3	MOLA	AÇO INOX AISI 316
4	CONTRA SEDE	AÇO INOX ASTM A 351 GR. CF8M
5	ANEL DE VEDAÇÃO	PTFE

OPÇÕES DE MATERIAIS

- BRONZE ASTM B62 C83600
- BRONZE ALUMÍNIO B148 C95200
- BRONZE ALUMÍNIO B148 C95500
- BRONZE ALUMÍNIO B148 C95800
- AÇO CARBONO ASTM A216 GR. WCB
- AÇO INOX ASTM A351 GR. CF8

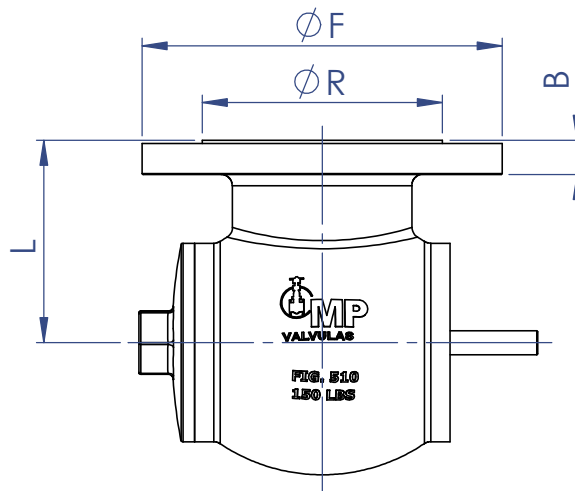

DN	L	F	R	B	C	N	K
2"	76	150	92,1	19,1	120,7	4	3/4"
3"	107	190	127	23,9	152,4	4	3/4"

Construção conforme Padrão fabricante
Flanges conforme ANSI B16.5 para Aço
e B16.1 para Bronze
Teste conforme API 598

